

The Triton LED Series is an indoor or outdoor, die-cast, architectural, high-performance LED fixture designed to work in emergency lighting and combined general/emergency lighting applications.

Model: \_\_\_\_\_ Date: \_\_\_\_\_  
Accessories: \_\_\_\_\_  
Job Name: \_\_\_\_\_ Type: \_\_\_\_\_

**FEATURES & BENEFITS**

- Switchable AC operation for use as dusk to dawn with photocontrol option or use of a normally open switchLED
- A 1/2 inch NPT threaded conduit opening is provided at the top of the enclosure and sealed with a closure plug
- Optional cold weather package -4°F to 122°F (-20°C to 50°C)
- UL Listed 90 minute emergency run time, 24 hour recharge time
- Suitable for Wet or Damp Locations



**SPECIFICATIONS**

- Illumination:** Long lasting, energy efficient, ultra-bright white 11W, 5000K CCT LED
- Housing:** Low-profile, streamlined, die-cast aluminum housing
- Input:** 120/277VAC Dual primary, 60Hz
- Battery:** Maintenance-free NiCad battery
- Operating Temp:** 0°C to 50°C (32°F to 122°F)
- Run Time:** cULus Listed 90 minute emergency run time, 24 hour recharge time
- Mounting:** Universal J-box mounting pattern or surface wiring through top conduit power feed
- Finishes:** Black, dark bronze, silver or white
- Options:** CL - Cold Location package, suitable for temperatures from -20°C to 50°C (-4°F to 122°F)
- Certifications:** cULus Listed for Damp or Wet Locations, meets or exceeds UL 924, NEC requirements and NFPA 101
- Warranty:** Any component that fails due to a manufacturing defect is guaranteed for three years with a separate two year prorated warranty on the battery. The warranty does not cover physical damage, abuse or instances of uncontrollable natural forces.

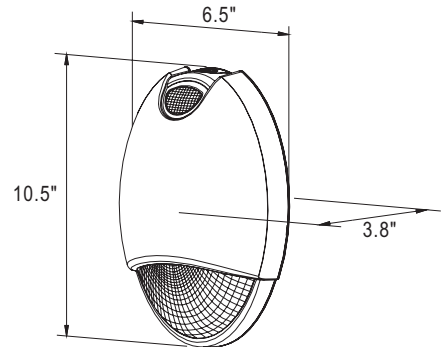

**ORDERING INFORMATION Example: TRL-ACEM-BR-CL**

Series	Product Category	Finish	Options (Factory Installed)
TRL	ACEM <sup>1</sup> = Normally on with Emergency Lighting	BL = Black	CL = Cold Location Package
		BR = Dark Bronze	
		SA = Silver	
		WH = White	

<sup>1</sup> "Normally off" standby battery backup operation is available. See installation instructions for details.

## CONSTRUCTION

Our Triton LED Series offers a decorative, low-profile, architectural design with die-cast aluminum housing and durable powder coated finishes in silver and dark bronze. The Triton LED Series can be switched on and off by the integrated photocontrol or by a normally open switch while maintaining UL 924 compliance. The unit features a fully sealed and gasketed enclosure for Damp and Wet Location applications.

## ILLUMINATION

Units come standard with a single 11W high-performance LED featuring 1080 lumens in AC mode and 260 lumens in emergency backup mode, 5000K CCT and a CRI of 70. Features a UV-stable mirror-bright reflector and prismatic polycarbonate refractor for ideal light output.

## ELECTRICAL

### Input

Dual-voltage input 120 or 277VAC @ 60Hz.

### Nickel Cadmium Battery - NiCad (With Battery Only)

Exitronix NiCad batteries are maintenance-free with a life expectancy of 15 years. NiCad batteries offer high-discharge rates and continue to perform in a vast temperature range from 0°C to 50°C (32°F to 122°F). Cold Location (CL) option temperature range is -20°C to 50°C (-4°F to 122°F)

### Emergency

The Triton LED will operate for a minimum of 90 minutes during a loss of power with a 24 hour maximum recharge time for the battery.

### Low Voltage Disconnect

Low Voltage Disconnect (LVD) measures the battery terminal voltage. The LVD continuously monitors the battery terminal voltage and if it should fall below a preset voltage threshold, the LVD will disconnect the load. When the battery is recharging and voltage is raised above another preset voltage threshold, the load is automatically reconnected.

### Test Button

The test button is easy to locate and provides manual verification of the transfer circuit and emergency lamps.

## INSTALLATION

Universal J-box mounting pattern or surface wiring through the top conduit power feed make installation quick and easy.

### Wet Location Rated (Standard)

Wet Location Rated fixture that allows water or other liquids to drip, splash or flow on or against. The construction prevents the accumulation of water on live parts.

## Guardian Self-Test/Self-Diagnostics

The Guardian provides self-testing and self-diagnostic capabilities to the unit equipment.

At predetermined intervals, the unit equipment will automatically switch into battery mode. The unit equipment will also perform various self-diagnostic tests of the unit. Visual signaling will alert maintenance personnel to a fault of the unit equipment electronics, emergency lamp(s), battery and/or battery charger. The circuitry continuously monitors the operating condition of the unit equipment and battery charging circuit/battery supply voltage.

The unit equipment will automatically switch to battery mode every 28 days for a period of one minute. The unit equipment will automatically switch to battery mode every six months for a period of 30 minutes.

## CONFORMANCE TO CODES & STANDARDS

The Triton LED Series is UL Listed and meets or exceeds the following: UL 924, NEC requirements and NFPA 101.

## ON-CENTER SPACING

(Using multiple units mounted at a typical 9 foot height, 85/50/20 reflectance)

Model	# of LED Lamps	3' Path, 6' Corridor	6' Path, 6' Corridor
TRL-ACEM	1	32' (9'MH)	30' (9'MH)